

MARPORT CATCH SENSORS

QUICK REFERENCE GUIDE

Purpose

Marport's catch sensors tell you when your trawl starts to fill. Placed on the top of the trawl codend, they monitor the amount of catch that you have and warn you when the trawl is full. You can even use them to determine a precise amount of fish inside the trawl net. This way, you can monitor the contents of the codend as you are fishing, avoid problems of overfilling and increase the quality of the fish brought aboard. It is recommended to install several sensors along the trawl to better follow the filling process. There are two types of catch sensors:

- **Catch sensor:** gives you the catch status of the trawl (empty or full), along with depth, water temperature and pitch and roll information. Catch sensors can emit on a single frequency of 40 kHz (Marport, Scanmar) or 70 kHz (Simrad, Wesmar), or on a dual frequency (40 kHz/70 kHz).
- **Catch Explorer:** gives you the catch status of the trawl, with depth, water temperature and pitch and roll information. In addition, it provides an echogram image of the volume of catch inside the codend.

Firmware

Product Name	Specific Options
Catch	<ul style="list-style-type: none"> • Catch status • Depth, temperature, pitch & roll • Catch hybrid 70: compatible with Simrad 70 and Wesmar • Catch hybrid PI: compatible with Simrad PI
Catch Explorer V2	<ul style="list-style-type: none"> • Catch status • Depth, temperature, pitch & roll • Echogram
Catch Explorer V3	<ul style="list-style-type: none"> • Catch status • Depth, temperature, pitch & roll • Echogram with target strength values

Dimensions

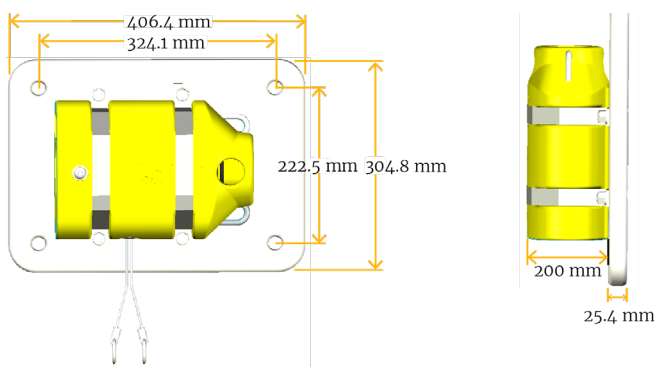

Main Parts

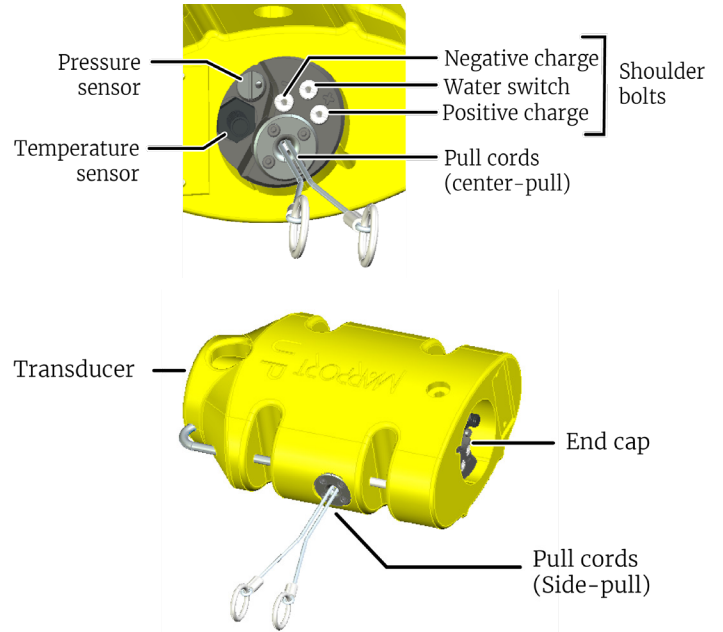

- ⚠ Caution:**
- Do not insert foreign objects into depth sensor opening or try to open it.
 - Do not remove the shoulder bolts from the outside of the sensor. It may damage the components.

Sensor Configuration

Sensors can be fully configured from the vessel or from the office using a wireless connection with Marport Mosa2 configuring tool, on any Mac Os device.

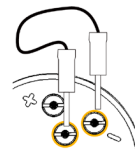

To activate the sensor outside sea water, use a jumper to connect and disconnect the negative charge and the water switch.

Refer to the LED in the transducer to see the state of the sensor:

State	Situation	Action	LED
Charging	Charger plug is connected.	Batteries are charging.	No light
Running	Sensor is in water or activated with jumper.	After an initialization phase, echo sounder is operating.	Flashing red
Configuring	Sensor is out of water.	Configuration via wireless connection. Turns off after 10 min. without user action.	Flashing green

- M!** With Mosa2 configuring tool, you can:
- Configure all settings for your sensor
 - Export the sensor settings

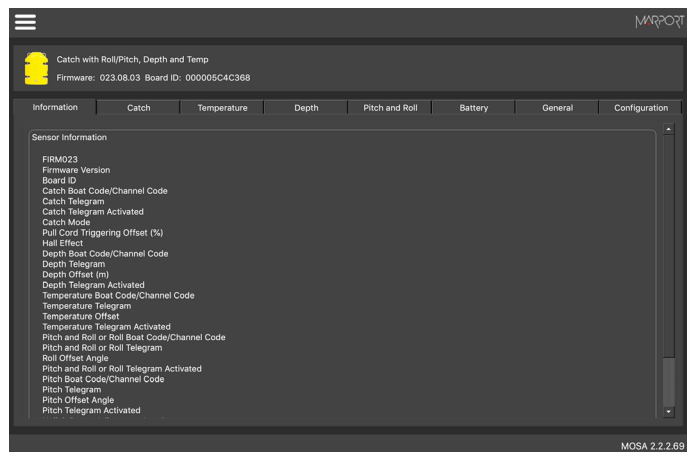

Note: Only advanced users or Marport technicians should configure the sensor. For further information, refer to catch sensor user guide.

System Configuration

Firmware	Receiver version	Scala version
Catch	all	all
Catch Explorer V2	04.02.02 or later	01.00.04 or later
Catch Explorer V3	04.02.28 or later	01.02.05 or later

- M!** Add your catch sensors to the receiver with Marport Scala2 software.

When adding the sensor to the receiver:

- Make sure that your sensor configuration (Mosa2) and receiver configuration (Scala2) are identical, especially the uplink frequency of the sensor.
- Make sure there is enough distance between the sensor frequency and other sensor frequencies.

For further information, refer to catch sensor user guide.

Installing

Sensors can be installed with the pull cords on the side or on the center of the sensor.

Pull cords are attached to the net. When the net fills up and the meshes expand, cords are pulled and this triggers the catch sensor.

You can install a stabilization board for Catch Explorer sensors.

If the meshes of the net obstruct the Catch Explorer signal, you can install the sensor inside the codend.

1. Install the sensor on the top of the codend with the UP side of the housing oriented toward the vessel. Make sure there is nothing in front of it that would block its signal.

2. Securely attach the sensor to the net by its front and back attachment lugs:
 - a. When you attach the sensor, stretch the net codend at the point where you need the catch status to become full.
 - b. Once installed, make sure that when the net is fully stretched out, it does not cause stress on the attachment points.
3. If you use a stabilization board:
 - a. Put the mounting straps through the lugs on the sides of the housing and fix them to the board.
 - b. Attach the stabilization board with rope to prevent rapid wear on the board.
4. Attach one end of each rubber strap to the pull cords of the sensor, and the other ends to the net. Make sure the pull cords are taut enough to trigger when the net is full, but loose enough not to trigger when the net is empty.

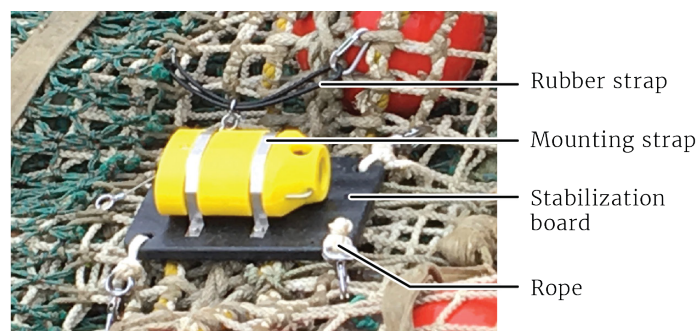
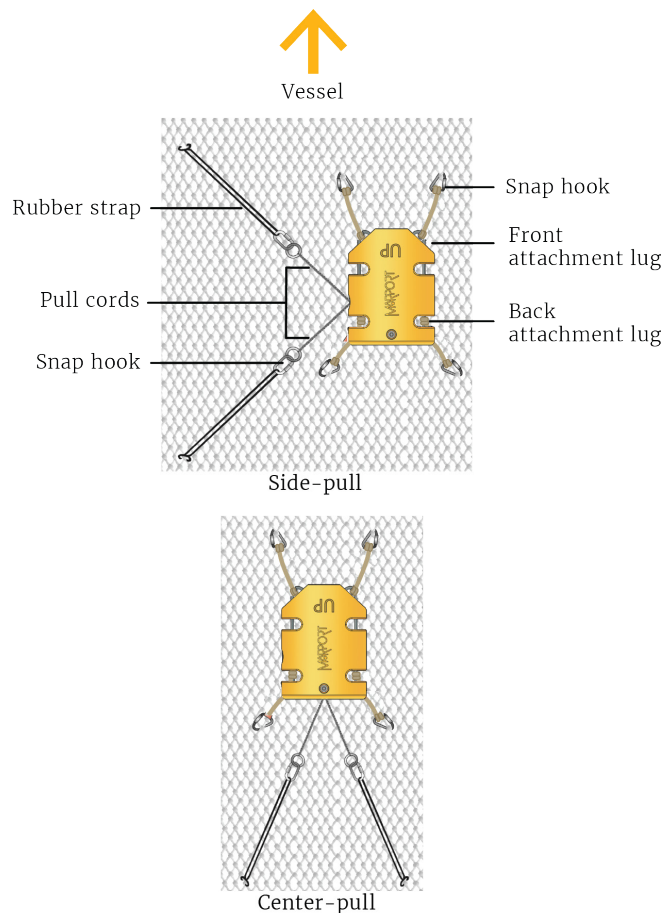

Display

Sensor data such as catch status, depth, temperature, pitch and roll are displayed on Scala2 software.

You can customize their display types:

- Text
- History Plot
- Dial
- Gauge

Catch sensors have different features to help you monitor your trawl. These features depend on your type of sensor and version.

Catch

- **Catch monitoring:** sensor detects when the net is full.
- **Pitch & Roll**
- **Depth**
- **Temperature**

Catch Explorer

A Catch Explorer has the same features as a Catch sensor. In addition, it displays echogram images of the codend.

- **Target strength (V3):** Target strength of individual targets is displayed on the echogram when you hover over it with your mouse. It helps you identify fish.
- **Autorange (V2, V3):** The range of the sounding can adapt automatically to the bottom detected. This enables you to have better echogram image quality when the trawl opening is small, because the range will become smaller (the smaller the range, the better the image quality).
- **TVG:** Pings sent by the sensor are attenuated in the water. It means the deeper the target is, the more attenuated signals will be received and sent back. TVG (time variable gain) is here to compensate this effect by using a lower gain level when signals travel toward a target at a small distance and higher gain level when signals travel toward deeper targets. The end result is to compensate sounding attenuation and therefore to show a same target strength for a same target at different depths.

For a Catch Explorer, it is recommended to set TVG at 20 log for better target strength values of the bottom and schools of fish.

Below are examples of data displayed by catch sensors.

Catch

Examples of 3 catch sensors with depth, pitch and roll.

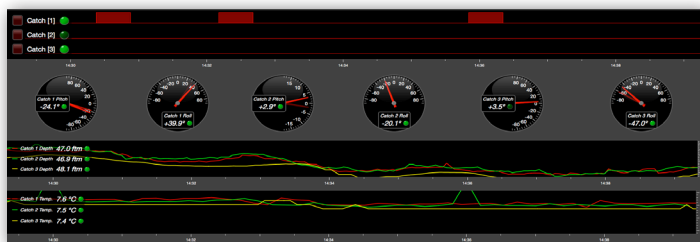

Catch Explorer

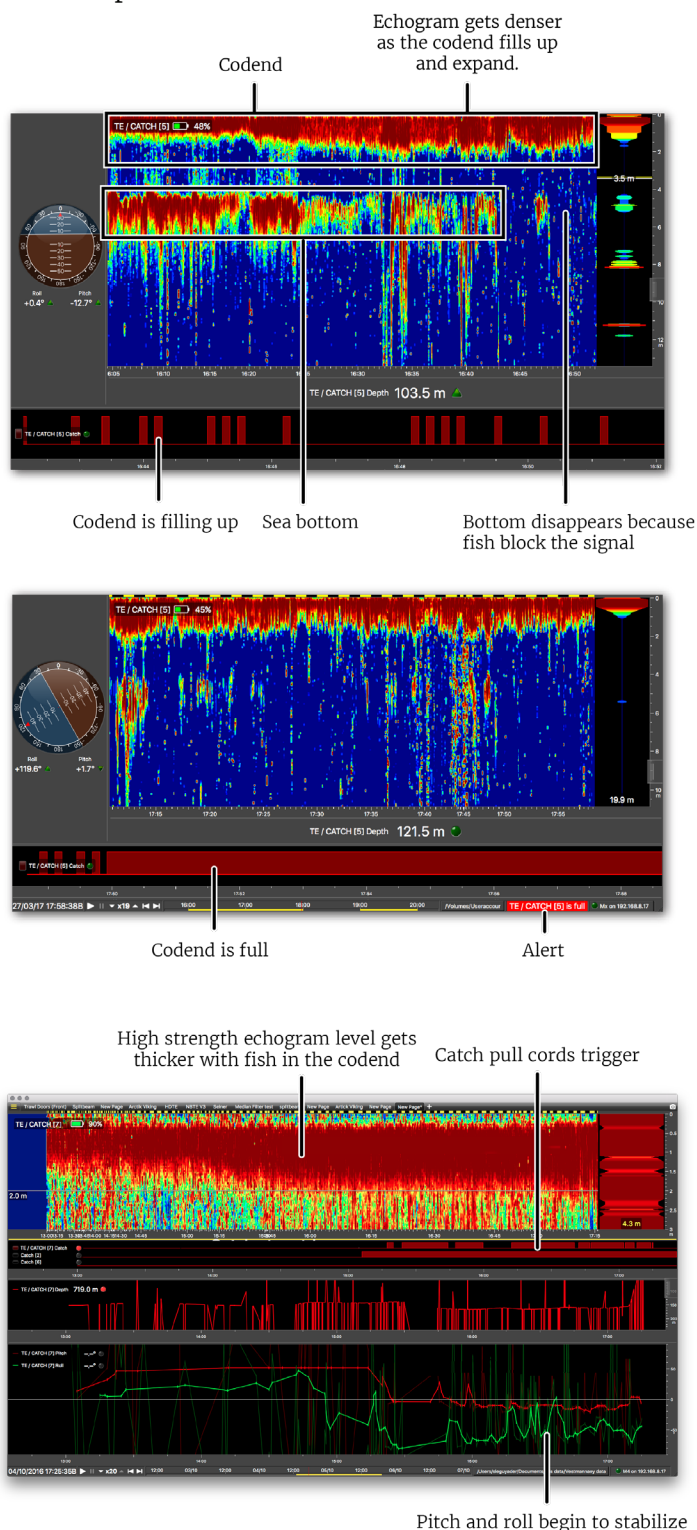

Pitch and roll begin to stabilize

Sensor Daily Use



The sensor automatically starts when in sea water. It switches to wireless connection mode when out of water. When in wireless mode, the sensor turns off after 10 minutes if there is no user action.

When the sensor is not in operation, verify with the transducer LED that the unit is not in running mode and discharging the batteries.

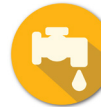

Rinse the sensor with fresh water between uses, especially the negative, positive charges and water switch (see illustration p.1). You can do it when the sensor is in running mode out of water. Dry the charging bolt afterwards.



The operational life time can be up to 740 hours for a catch sensor and 19 hours for a Catch Explorer, depending on the power settings and options.

Catch sensors have Lithium-Ion batteries. Charge them with Marport Basic Sensor Charger or Multi-Charger. Avoid full discharges and charge the battery whenever possible, at any battery level.

Maintenance

External

- Check that all attachment equipment are not worn or torn. Replace when appropriate.
- Make sure that the sensor is clean. Remove debris with a piece of wood or screwdriver. Wash away mud or debris with warm water but do not use highly abrasive materials.

⚠ Be careful with the sensor. Sensors and components are sensitive to mechanical shocks and contamination.

Internal

Only an approved Marport dealer can access the internal unit. Warranty will become void if anyone other than an approved dealer tries to do internal maintenance duties on sensors.

Dealers, please refer to the catch sensor service manual for more detailed maintenance instructions.

Marport recommends you to return sensors to an approved Marport dealer every 2 years for maintenance.

⚠ To ensure proper and safe use of this equipment, carefully read and follow the instructions in the catch sensor user guide.

Offices

France

Marport France SAS
8, rue Maurice Le Léon
56100 Lorient, France
supportfrance@marport.com

Iceland

Marport EHF
Fossaleyni 16
112 Reykjavík, Iceland
supporticeland@marport.com

Spain

Marport Spain SRL
Camino Chouzo 1
36208 Vigo (Pontevedra) Spain
supportspain@marport.com

USA

Marport Americas Inc. USA
12123 Harbour Reach Drive
Mukilteo, WA 98275 USA
supportusa@marport.com

©2020 Marport. All Rights reserved.

No part of this document may be reproduced, stored in a retrieval system or transmitted in any form by any means; electronic, mechanical, photocopying or otherwise, without the express written permission from Marport. "Marport", the Marport logo and Software Defined Sonar are registered trademarks of Marport. All other brands, products and company names mentioned are the trademark and property of its respective owners only. Marport is a division of Airmar Technology Corporation.